

Charging for VL series

■ Charging circuits

Charging / discharging cycle	Approx. 1000 times at 10% discharge depth to nominal capacity
Charging system	Constant-voltage charging (Please strictly adhere to the specified charge voltage)
Operating temperature	-20°C to +60°C

*Consult with Panasonic Energy concerning constant-current charging systems.

The charging circuit is crucial in terms of ensuring that full justice will be done to the battery characteristics.

Consider it carefully as the wrong charging circuit can cause trouble.

■ Precautions regarding the charge voltage setting

Under no circumstances should trickle charging, which is used for nickel-cadmium batteries, be used.

Ignoring this precaution will cause the battery voltage to rise to about 5V, resulting in a deterioration of performance.

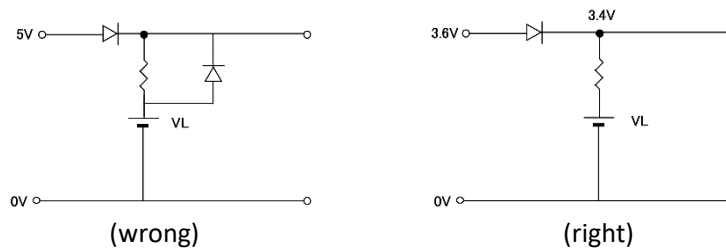

■ Charge voltage range

If a fixed-charging method is applied, please adhere to the specified charging voltage.

The guaranteed value over an operating temperature range from -20 to +60°C is $3.4 \pm 0.15V$. (Actual value : $3.4 \pm 0.20V$)

*If the charging voltage exceeds the specifications, the internal resistance of the battery will rise and may cause battery deterioration. Also, with a charge voltage around 4V, corrosion of the (+) terminal (case) may occur, causing leakage.

*It is not possible for the battery capacity to recover completely when the charging voltage is below the specification.

■ Recommended charging circuits

● Basic conditions

Charge voltage: $3.4 \pm 0.15V$

Charge current: For a battery voltage of 3V

VL1220 Approx. 0.5mA or below

VL2020 Approx. 1.5mA or below

VL2330 Approx. 2.0mA or below

VL3032 Approx. 4.0mA or below

(It is permissible for the current to increase beyond the above level when the battery voltage drops below 3V.)

■ Mixed usage of batteries

Do not use these batteries and primary lithium batteries or other rechargeable batteries together, and do not use new batteries and old batteries together even if they are of the same type.

Example of Charging Circuits for VL series

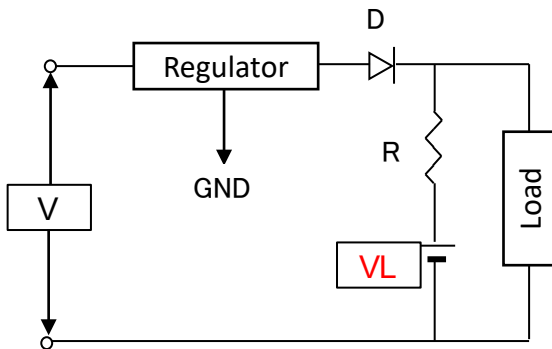

Standard Circuit

Diode D: RB751VM-40

Model	Reg.	R
VL1220	3.5V	750Ω
	3.4V	510Ω
VL2020	3.5V	240Ω
	3.4V	180Ω
VL2330	3.5V	180Ω
	3.4V	130Ω
VL3032	3.5V	91Ω
	3.4V	68Ω

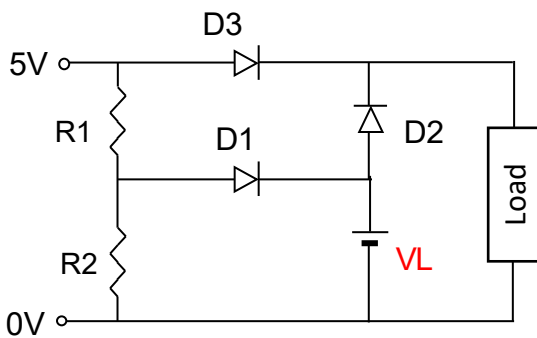

Standard Circuit (Charging from 5V line)

Diode D: RB751VM-40

Model	R1	R2
VL1220	750Ω	1.8KΩ
VL2020	240Ω	590Ω
VL2330	200Ω	510Ω
VL3032	68Ω	180Ω

For diode D2, select a diode of small inverse current ($I_R=1\mu A$ below / 5V)

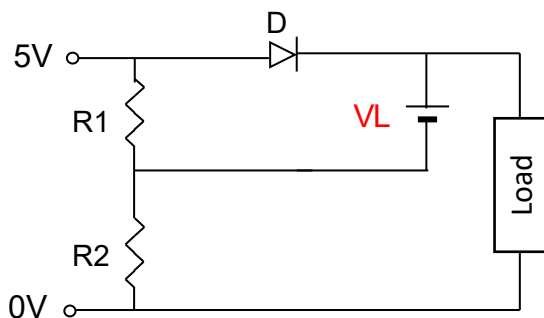

Cost performance type

During charging, there is voltage drop V_f at D.

Diode D: RB751VM-40

In case the current flows through D is less than 1mA, when the battery is full charged.

Model	R1	R2
VL1220	1.8KΩ	750Ω
VL2020	590Ω	240Ω
VL2330	510Ω	200Ω
VL3032	180Ω	68Ω

If the current exceeds 1mA, these value of resistances is different.

Charging characteristics

